

# Manital York Passage Set Template & Fitting Instructions

Always check measure the template before using it to make sure the template measurements are accurate. Templates can shrink with printing!

## For “York” Passage Sets Only

1. Mark Door at 60mm backset from door edge.
2. Drill spindle centre hole 16-20mm in diameter.
3. The York Passage set is surface mounted to the door. **DO NOT DRILL** through fixing screw holes.
4. Mark the centre-line for the latch hole in the door edge. Drill 25mm diameter hole for the latch and check out the door edge for the face plate.

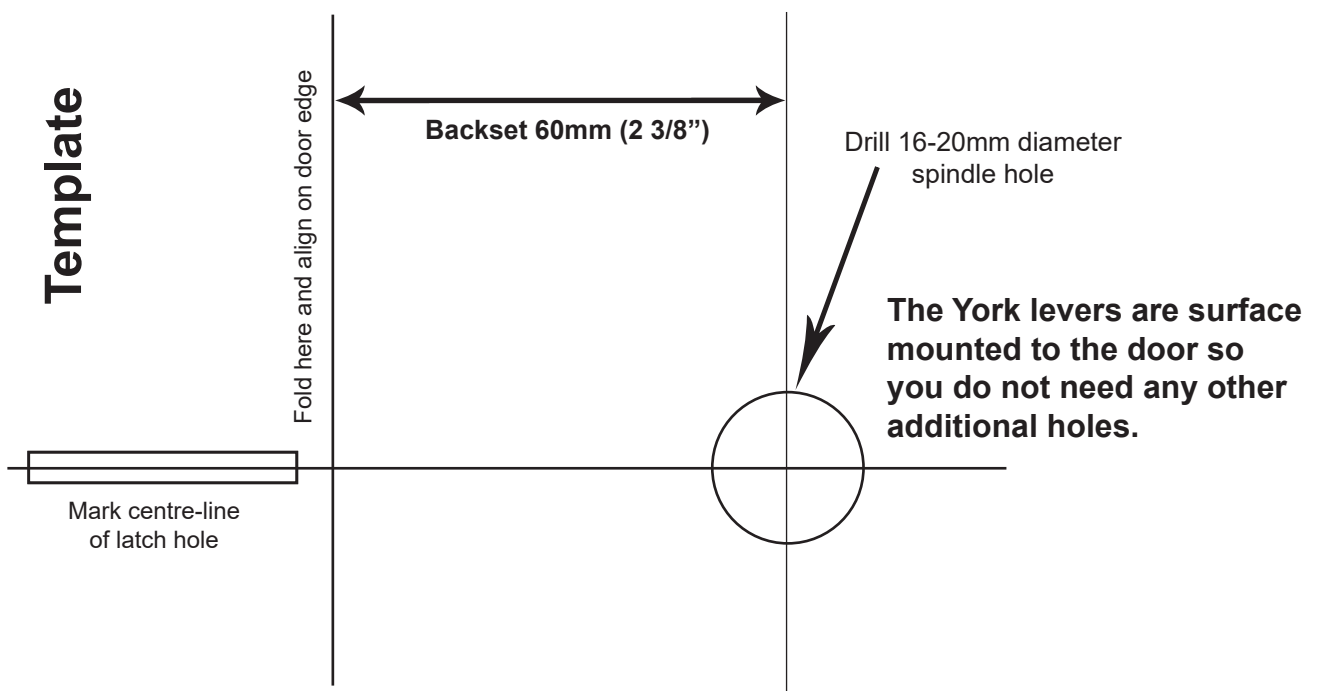

5. Insert latch into door edge and fix with wood screws.
6. Insert 7.6mm thick spindle (95mm or 105mm in length) through the centre of the latch cam.
8. Mount the levers over the spindle on both sides of the door and secure to the door with the surface mounting wood screws provided.
10. Secure the levers to the spindle by tightening the grub screws on the lever neck on both sides of the door.
11. Check that the levers function correctly.